

\* OAH013

Pos	Code	Description
1	XH.LM.20.03.CA.LE	Lift arm LM.20.03 + Snr
2	XF.SM.20.03.CA.O.VK	Frame SM.20.03 + Snr
3	V151.R.24	Valve hydro motor -R- 24V
3	V151.R.12	Valve hydro motor -R- 12V
3	V151.L.24	Valve hydro motor -L- 24V
3	V151.L.12	Valve hydro motor -L- 12V
4	V144.24	Valve hydr.stabilising leg 24V
4	V144.12	Valve hydr.stabilising leg 12V
5	P050.B	Hydro motor SM -B-
6	M5404	Bearing bush gear wheel
7	M5403.L	Support hydro motor L
8	M5400.102.B	Gear wheel female 102mm
9	M5400.102.A	Gear wheel male 102mm
10	M1986.25	Roller sliding bracket
11	M1940.5	Ring sliding bracket ø40x5
12	M1912.42.2	Washer ø42/ø12.5 x 2mm
13	M1835.25T	Bearing bush ø35x25mm
14	M1830.30T	Bearing bush ø30x30mm
15	M1825.25T	Bearing bush ø25x25mm
16	M1735.094.P50.L	Pin ø35x94 - 50cc
17	M1730.147.P35.D	Pin ø30x147mm - 35cc

Pos	Code	Description
18	M1730.138.P50	Pin ø30x138mm - 50cc
19	M1730.093.P50.L	Pin ø30x93mm - 50cc
20	M1725.078.BO08	Pin ø25x78mm - BO08
21	M1704.12.6	Nut grease nipple M12-M6
22	M1333.180	Swing bracket LM.20.03 - 180cc
22	M1333.170	Swing bracket LM.20.03 - 170cc
23	M1127.SM	Plate hydr.stabilising leg SM
24	M0875.3	Ring roller DHSM ø30/45x3mm
25	M0502.150.SM8	Closing plate 150 SM80
26	KSM0002.R	Fixation hydraulic pipe R SM80
27	KSM0002.L	Fixation hydraulic pipe L SM80
28	CH51.R	Lift cylinder right CH51 + Snr
29	CH51.L	Lift cylinder left CH51 + Snr
30	GE.S.R-V02	Hydr.power pack right + Snr
31	GE.S.L-V02	Hydr.power pack left + Snr
32	E0562.125	Fixation bracket frame E0550.29 125mm
33	E0550.29	Corrugated pipe ø29mm /m
34	CS38.D.Z.R	Tilt cylinder right CS38.D.Z + Snr
35	CS38.D.Z.L	Tilt cylinder left CS38.D.Z + Snr
36	CAD14.D.R	Stabilising leg right CAD14.D + Snr
37	CAD14.D.L	Stabilising leg left CAD14.D + Snr

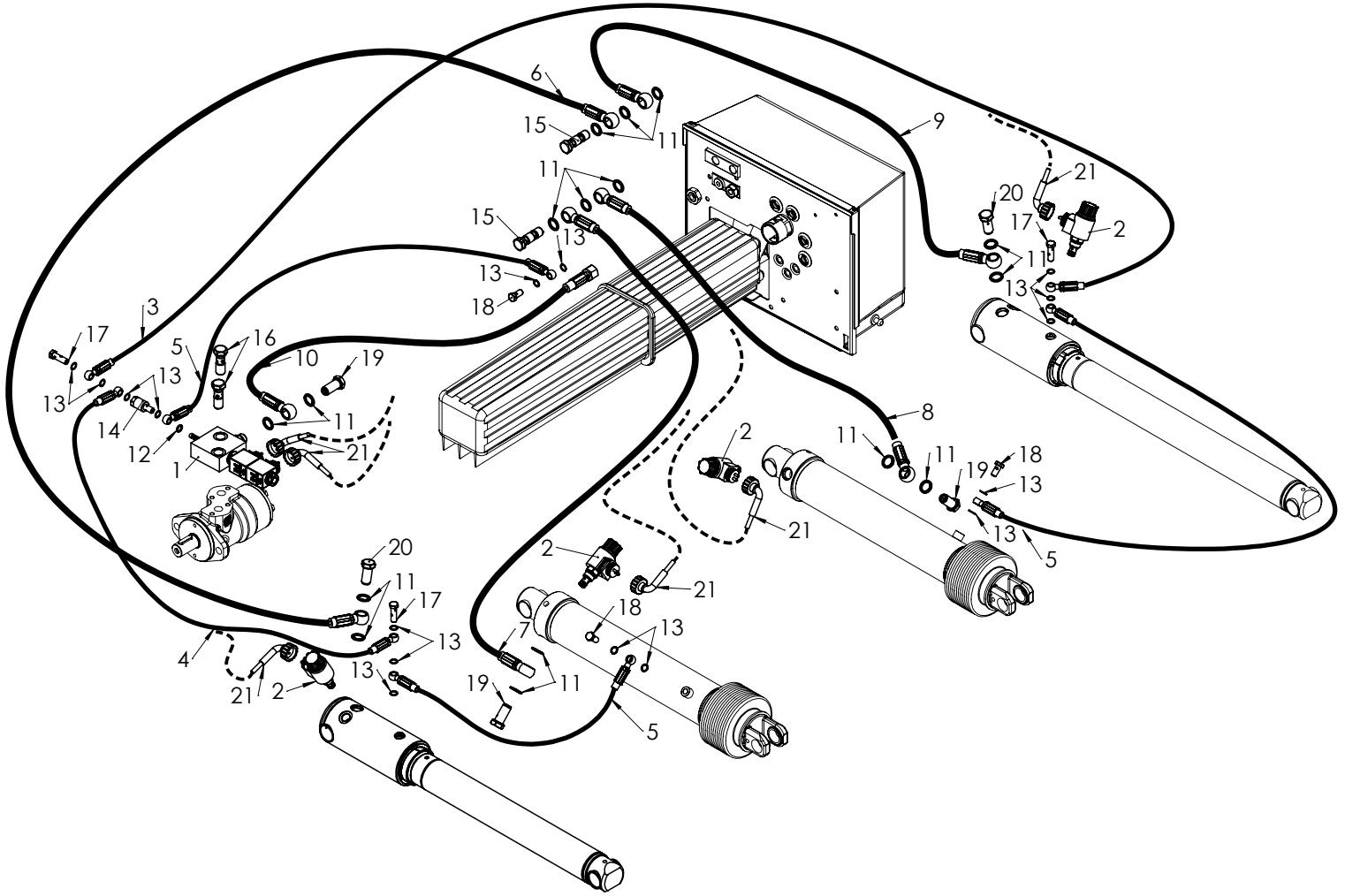

Pos	Code	Description
1	V151.R.24	Valve hydro motor -R- 24V
1	V151.L.12	Valve hydro motor -L- 12V
1	V151.R.12	Valve hydro motor -R- 12V
1	V151.L.24	Valve hydro motor -L- 24V
2	V133.24.H	Safety valve SA 24V - HYDAC
2	V133.24	Safety valve SA 24V
2	V133.12.H	Safety valve SA 12V - HYDAC
2	V133.12	Safety valve SA 12V
2	V037.H	Safety valve SA 12V Hydac
2	V037	Safety valve SA 12V + E241
2	V036.H	Safety valve SA 24V Hydac
2	V036	Safety valve SA 24V + E240
* 3	KSL2500.OO	LP hose E-E 2500 mm
\$ 3	KSL2900.OO	LP hose E-E 2900mm
° 3	KSL2700.OO	LP hose E-E 2700mm
* 4	KSL1900.OO	LP hose E-E 1900mm
\$ 4	KSL0950.OO	LP hose E-E 950mm
° 5	KSL0600.OO	LP hose E-E 600mm
* 5	KSL0500.OO	LP hose E-E 500mm
* 6	KSH2550.OO	HP hose E-E 2550mm

Pos	Code	Description
\$ 6	KSH3200.OO	HP hose E-E 3200 mm
° 6	KSH3000.OO	HP hose E-E 3000 mm
* 7	KSH2300.OO	HP hose E-E 2300mm
\$ 7	KSH3100.OO	HP hose E-E 3100mm
° 7	KSH2900.OO	HP hose E-E 2900 mm
* 8	KSH1900.OO	HP hose E-E 1900mm
° \$ 8	KSH1000.OO	HP hose E-E 1000mm
* 9	KSH1700.OO	HP hose E-E 1700 mm
* 10	KSH0550.MO	HP hose E-N 350mm
\$ ° 10	KSH0320.MO	HP hose E-N 350mm
11	K0700.3-8	Sealing ring 3/8"
12	K0700.10x2	Sealing ring 10x2mm
13	K0700.10x1	Sealing ring 10x1mm
14	K0203	Coupling no return valve M10x1
15	K0188	Banjo double 3/8"
16	K0150	Banjo logical valve
17	K0112	Banjo double M10x1
18	K0110	Banjo simple M10x1
19	K0109.30	Banjo braking valve ø3
20	K0109.25	Banjo braking valve ø2.5
21	E0086	Cable safety valve Costal

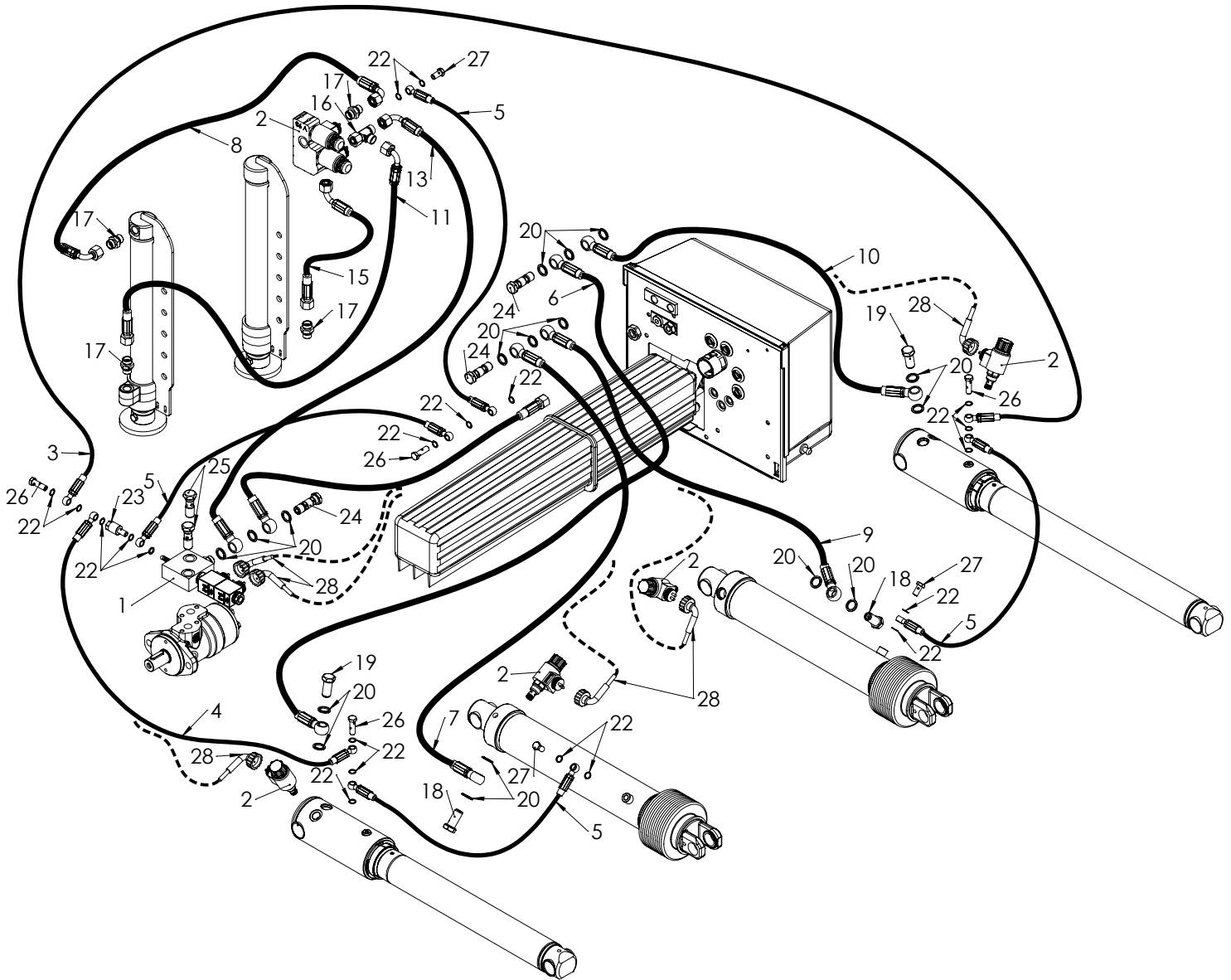

Pos	Code	Description
1	V151.R.24	Valve hydro motor -R- 24V
1	V151.L.12	Valve hydro motor -L- 12V
1	V151.L.24	Valve hydro motor -L- 24V
1	V151.R.12	Valve hydro motor -R- 12V
2	V133.24.H	Safety valve SA 24V - HYDAC
2	V036	Safety valve SA 24V + E240
2	V133.24	Safety valve SA 24V
2	V133.12.H	Safety valve SA 12V - HYDAC
2	V133.12	Safety valve SA 12V
2	V093.24	Valve hydr.stabilising leg 24V
2	V093	Valve hydr.stabilising leg
2	V037.H	Safety valve SA 12V Hydac
2	V037	Safety valve SA 12V + E241
2	V036.H	Safety valve SA 24V Hydac
\$	3	KSL2900.OO LP hose E-E 2900mm
*	3	KSL2500.OO LP hose E-E 2500 mm
o	3	KSL2700.OO LP hose E-E 2700mm
*	4	KSL1900.OO LP hose E-E 1900mm
o	4	KSL0950.OO LP hose E-E 950mm
\$	5	KSL0600.OO LP hose E-E 600mm
*	5	KSL0500.OO LP hose E-E 500mm
\$	6	KSH3200.OO HP hose E-E 3200 mm
o	6	KSH3000.OO HP hose E-E 3000 mm
*	6	KSH2550.OO HP hose E-E 2550mm

Pos	Code	Description	
\$	7	KSH3100.OO Hp hose E-E 3100mm	
*	7	KSH2300.OO HP hose E-E 2300mm	
o	7	KSH2900.OO HP hose E-E 2900 mm	
o	8	KSH2000.NN HP hose N90°- N90° 2000mm	
o	9	KSH1900.OO HP hose E-E 1900mm	
o	10	KSH1700.OO HP hose E-E 1700 mm	
o	11	KSH1700.MN HP hose N-N 90° 1700mm	
o	12	KSH1000.OO HP hose E-E 1000mm	
o	13	KSH0600.NO HP hose E-N 90° 350mm	
*	14	KSH0550.MO HP hose E-N 350mm	
\$	o	14	KSH0320.MO HP hose E-N 350mm
o	15	KSH0500.MN HP hose N-N 90° 500mm	
o	16	K1213 Coupling adjustable T 12	
o	17	K1201 Coupling straight 3/8"-12	
o	18	K0109.30 Banjo braking valve ø3	
o	19	K0109.25 Banjo braking valve ø2.5	
o	20	K0700.3-8 Sealing ring 3/8"	
o	21	K0700.10x2 Sealing ring 10x2mm	
o	22	K0700.10x1 Sealing ring 10x1mm	
o	23	K0203 Coupling no return valve M10x1	
o	24	K0188 Banjo double 3/8"	
o	25	K0150 Banjo logical valve	
o	26	K0112 Banjo double M10x1	
o	27	K0110 Banjo simple M10x1	
o	28	E0086 Cable safety valve Costal	

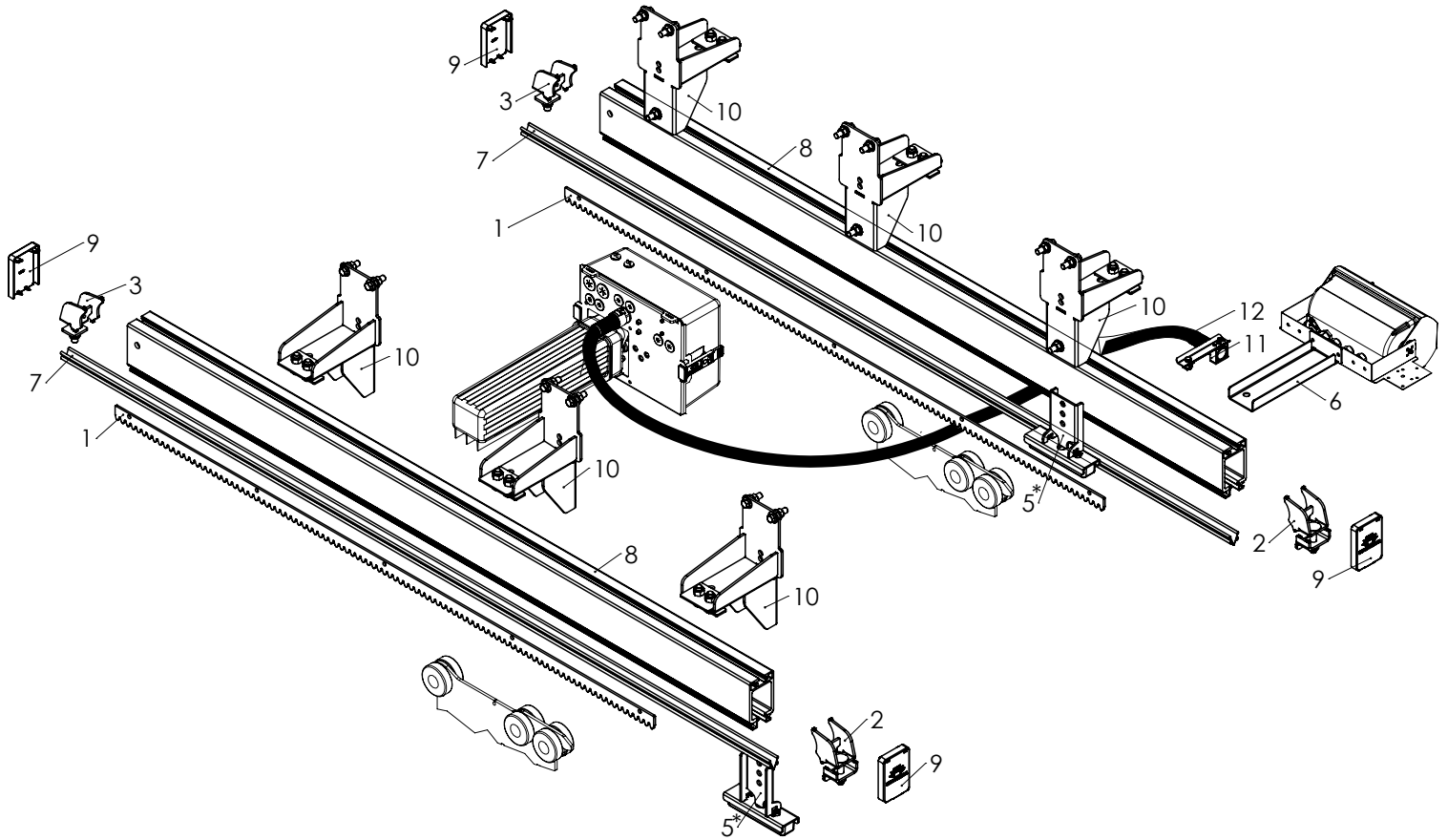

\* Option S257

### M5260.H.B

H=215mm, 385mm

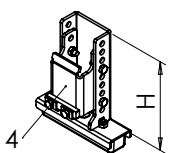

Pos	Code	Description
1	M5405.LE	Gear rack ...mm SM80
2	M5306.V	End stop front ALU AL207/AL208
3	M5306.A	End stop rear ALU AL207/AL208
4	M5260.0385.B	Support platform M1423 - 385mm
4	M5260.0215.B	Support platform M1423 - 215mm
5	M5250.B	Support platform SM - M1423
6	M5209.503	Support control box 503mm
6	M5209.303	Support control box 303mm
7	M5208	Rubber sliding tube
8	M5111.LE	Sliding tube alu SIDE ...mm
9	M1421	Cover sliding tube ALU M5111
10	M1170.295	Suspension side support 295mm
10	M1170.220	Mounting bracket SMP 240mm
10	M1170.170	Suspension side support 170mm
11	E0561.155	Fixation clip E560.29 155mm
12	E0550.29	Corrugated pipe ø29mm /m

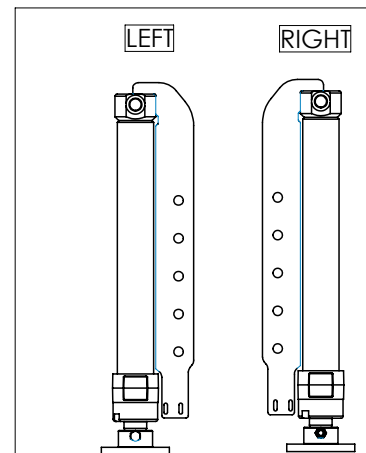
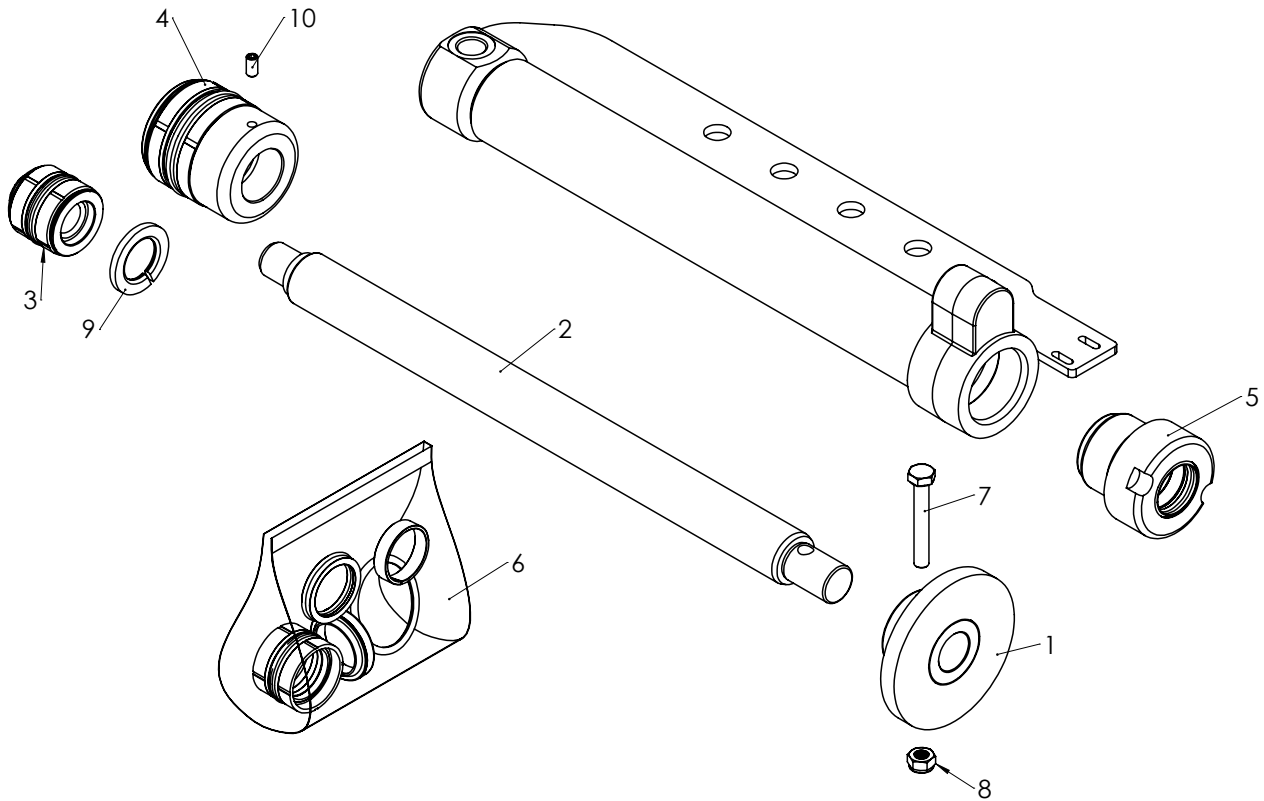

Pos	Code	Description
1	M4892.D.30	Foot hydr.stabilising leg CAD14 ø30
1	M4892.D.40	Foot hydr.stabilising leg CAD14 ø40
2	M4640.480.B	Rod cylinder ø40x480mm -B-
2	M4640.405	Rod cylinder ø40x405mm
2	M4630.425	Rod cylinder CAD14 ø30x425mm
3	M4535.040	Piston DA DKB ø40
4	M4503.060	Piston DA ø60
5	M4240.060.AG	Cylinder head SA ø60-40
5	M4230.040.AG	Cylinder head guide ø40-30
6	DSD060.40	Seal set DA ø60-40
6	DSD040.30	Seal set DA ø40-30
7	BT08.055	Bolt M8x55
8	BMB08	Locking nut M8
9	BC24.3	Spring washer M24 NMG452
10	BB06.12.PC	Allenbolt headless M6x12 PC

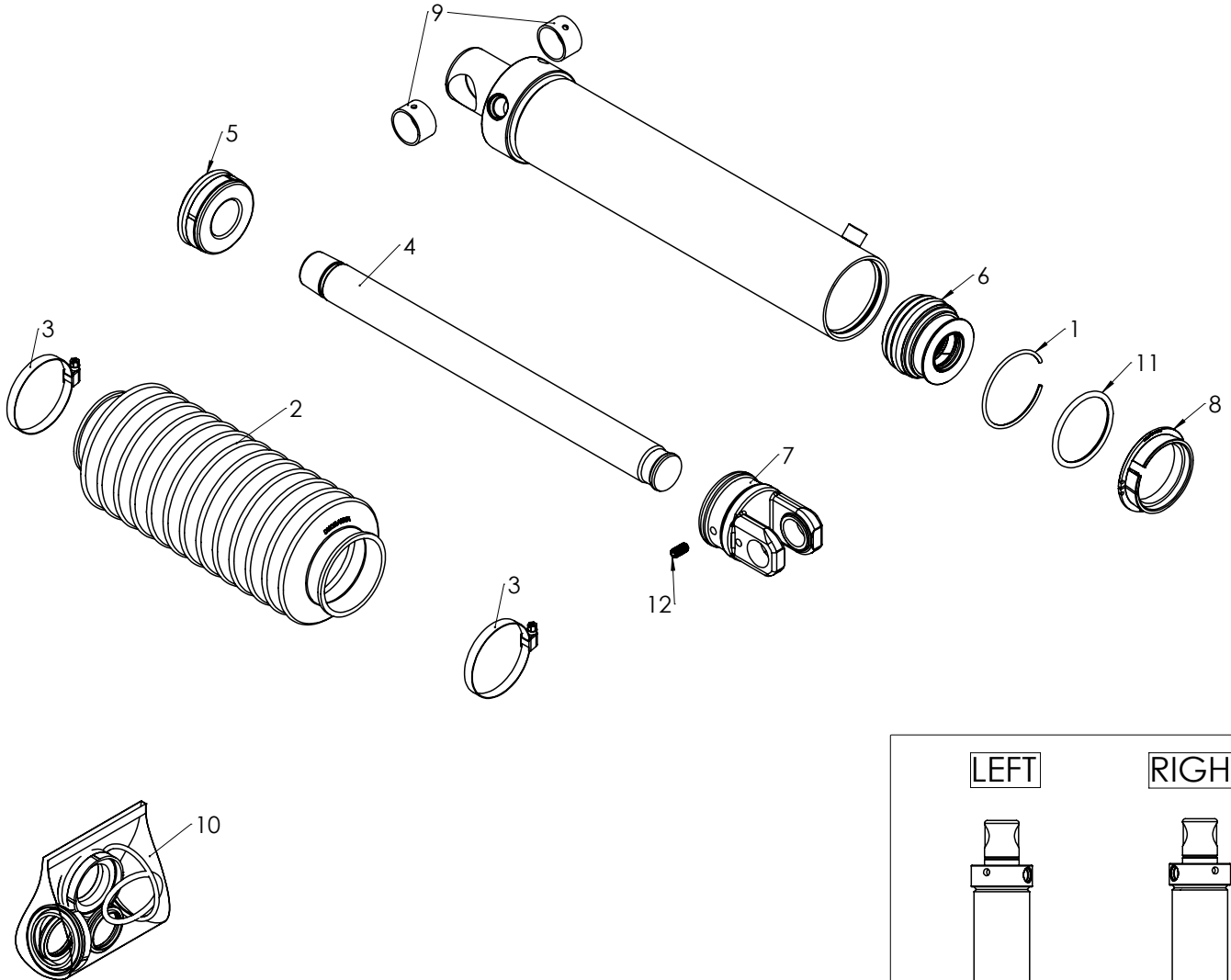
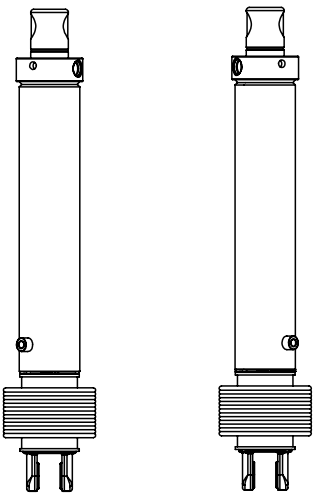
**LEFT**
**RIGHT**

Pos	Code	Description
1	VRX085.80	Spring ring ø80 mm
1	VRX085.60	Spring ring ø60mm
1	VRX085.70	Spring ring ø70
2	DSE080.40	Seal set SA ø80-40
2	DSE070.35	Seal set SA ø70-35
2	DSE060.35	Seal set SA ø60-35
3	M4929	Rubber sleeve 70x70
4	M4635.405	Rod OK311 D72 ø35x435mm
4	M4640.434	Rod OK310 ø40x434mm
4	M4635.503	Rod lift cylinder ø35x503mm
4	M4635.435	Rod OK311 D72 ø35x435mm
5	M1991.57	Ring cylinder dia 80
5	M1979.57	Ring cylinder Dia 70
5	BC52.983	Locking ring DIN983 ø52
6	M4440.080	Piston SA ø80-40

Pos	Code	Description
6	M4435.070	Piston SA ø70-35
6	M4435.060	Piston SA ø60-35
7	DO072.5	O-ring 72x5 mm
7	DO062.5	O-ring ø62x5
7	DO052.5	O-ring ø52x5
8	M4107.070.25.35.25.F	Fork lift cylinder Ø25 70cc Arm25
8	M4102.070.25.35.25.F	Fork rod ø35F L=70 (arm 25)
9	M4240.080.AP	Cylinder head ø80-40 -AP-
9	M4235.070.AP	Cylinder head ø70/35 AP
9	M4235.070.AC	Cylinder head with circlip ø70-35
9	M4235.060.AC	Cylinder head with circlip ø60-35 AC
10	M4901.070	Collar ø70
11	M1830.20T	Bearing bush ø30x20mm
12	BB08.16	Allenbolt headless M8x16

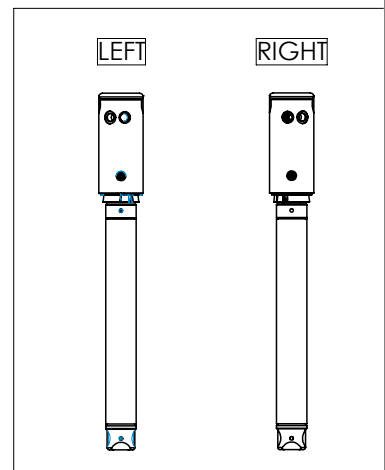
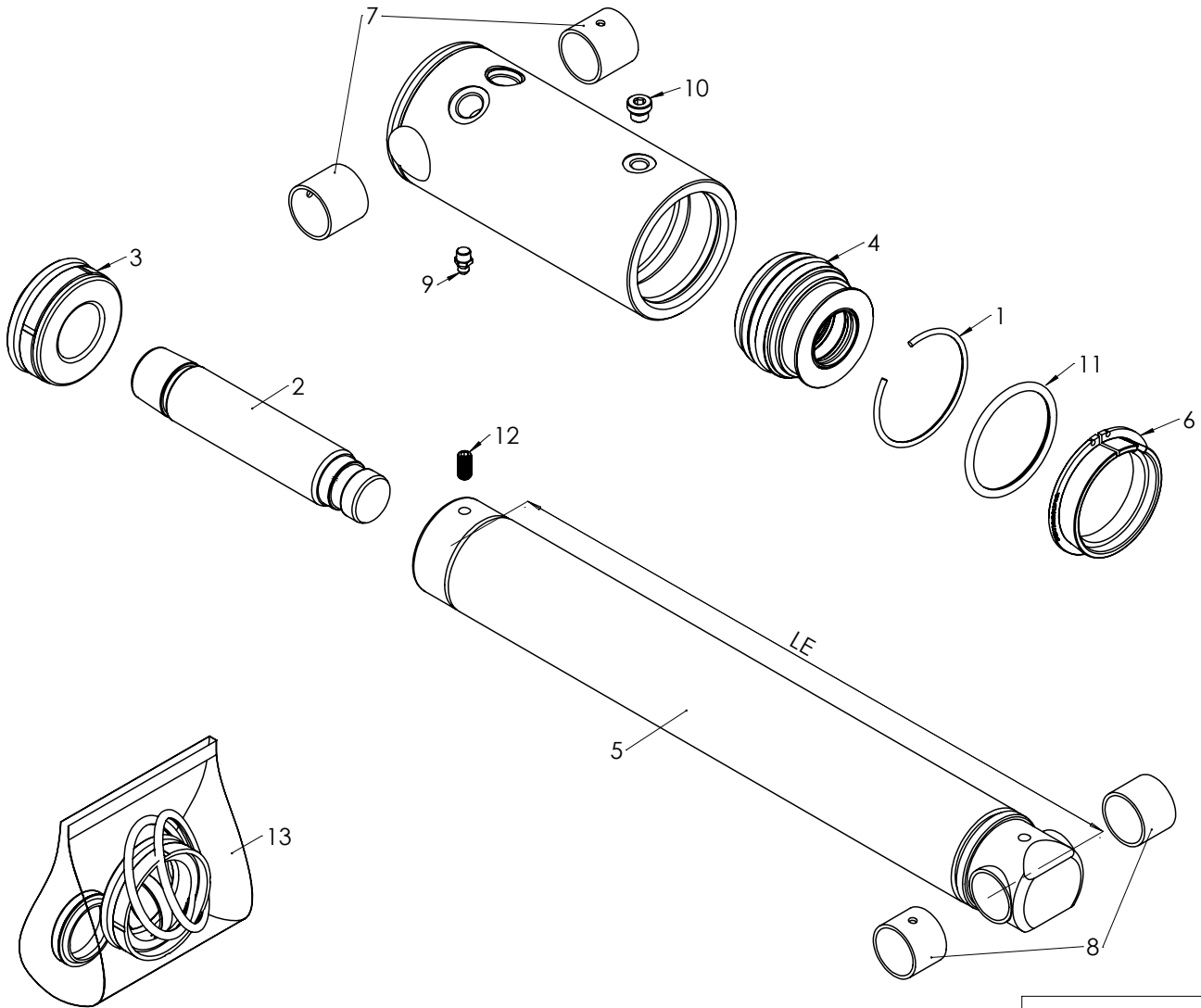

Pos	Code	Description
1	VRX085.80	Spring ring ø80 mm
1	VRX085.70	Spring ring ø70
2	M4640.180	Rod bolt-on SDS ø40x180mm
2	M4635.180	Rod bolt-on SDS ø35x180mm
3	M4440.080	Piston SA ø80-40
3	M4435.070	Piston SA ø70-35
4	M4240.080.AP	Cylinder head ø80-40 -AP-
4	M4235.070.AP	Cylinder head ø70/35 AP
5	M4040.865	Extension SDS L=865 ø30 -SM,SV
5	M4040.765	Extension SDS L=765 ø30 -SM,SV
5	M4040.705	Extension SDS L=705 ø30 -SM,SV
5	M4040.645	Extension SDS L=645 ø30 -SM,SV
5	M4040.585	Extension SDS L=585 ø30 -SM,SV

Pos	Code	Description
5	M4040.515	Extension SDS L=865 ø30 -SM,SV
5	M4040.465	Extension SDS L=500 SO
6	M1991.57	Ring cylinder dia 80
6	M1979.57	Ring cylinder Dia 70
7	M1830.30T	Bearing bush ø30x30mm
8	M1830.25T	Bearing bush ø30x25mm
9	M1701	Grease nipple M8
10	K0702.10	Closing cap M10x1
11	DO072.5	O-ring 72x5 mm
11	DO062.5	O-ring ø62x5
12	BB08.16	Allenbolt headless M8x16
13	DSE070.35.C	Seal set CIRCLIPS EW ø70-35
14	DSE080.40.C	Seal set CIRCLIPS EW ø80-40

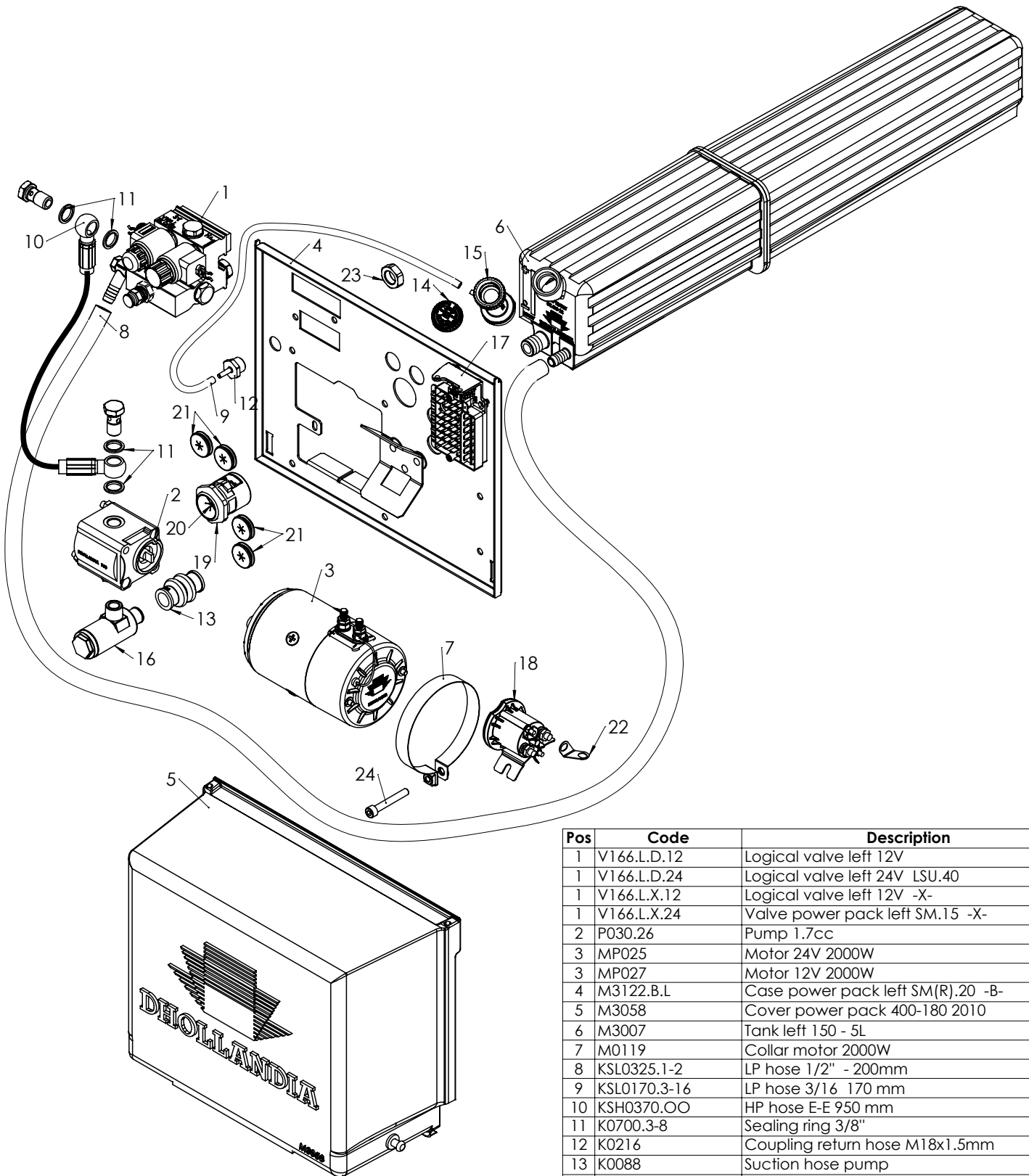

Pos	Code	Description
1	V166.L.D.12	Logical valve left 12V
1	V166.L.D.24	Logical valve left 24V LSU.40
1	V166.L.X.12	Logical valve left 12V -X-
1	V166.L.X.24	Valve power pack left SM.15 -X-
2	P030.26	Pump 1.7cc
3	MP025	Motor 24V 2000W
3	MP027	Motor 12V 2000W
4	M3122.B.L	Case power pack left SM(R).20 -B-
5	M3058	Cover power pack 400-180 2010
6	M3007	Tank left 150 - 5L
7	M0119	Collar motor 2000W
8	KSL0325.1-2	LP hose 1/2" - 200mm
9	KSL0170.3-16	LP hose 3/16 170 mm
10	KSH0370.OO	HP hose E-E 950 mm
11	K0700.3-8	Sealing ring 3/8"
12	K0216	Coupling return hose M18x1.5mm
13	K0088	Suction hose pump
14	F023	Extension tank incl. F024
15	F020	Filter compl. >2008..
16	E2051	Connection block hydr.power pack >2010
17	E0634.24	Relay round TRBT 24V 150A
17	E0634.12	Relay round TRBT 12V 150A
18	E0551.29	Muff chuck straight E550.29
19	E0093.21	Lead through rubber 21mm
20	E0093.12	Lead through rubber 12mm
21	E0064.R	Connection motor RIGHT
22	BMZ18.L	Nut low M18
23	BI08.055	Allenbolt with head M8x55
24	GK022	Air release cap orange 3/4



Drawing nr.:

**GE.S.R-V02**

Description:

**Hydr.power pack right + Snr**

Main group:

**Hydraulic power packs**

Subgroup:

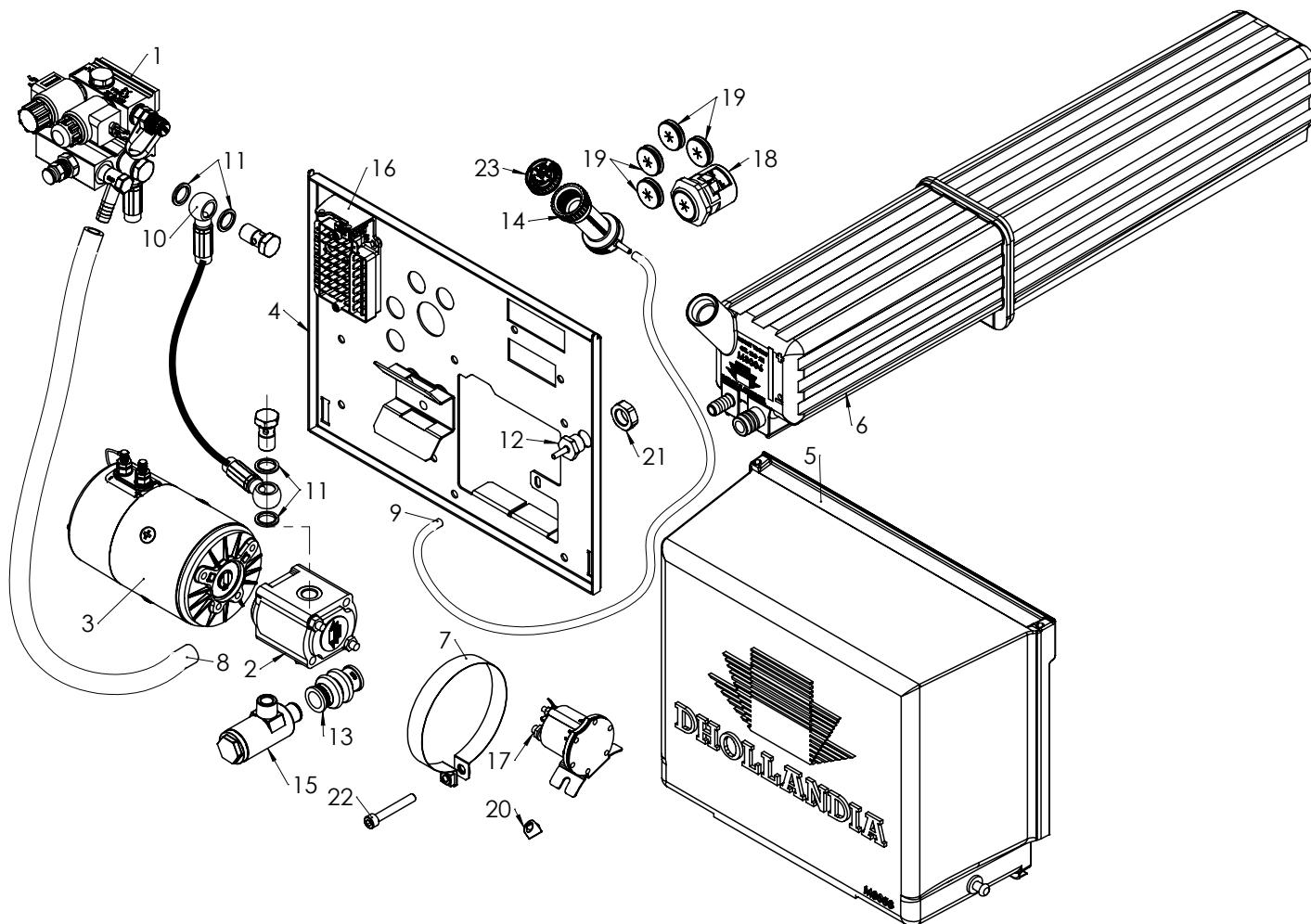
**Power packs with tank in tube**

Pos	Code	Description
1	V166.R.X.24	Valve power pack right SM.15 -X-
1	V166.R.X.12	Logical valve right 12V -X-
1	V166.R.D.24	Logical valve right 24V LSU.40
1	V166.R.D.12	Logical valve right 12V
2	P030.26	Pump 1.7cc
3	MP027	Motor 12V 2000W
3	MP025	Motor 24V 2000W
4	M3122.B.R	Case power pack right SM(R).20 -B-
5	M3058	Cover power pack 400-180 2010
6	M3006	Tank right 150 - 5L
7	M0119	Collar motor 2000W
8	KSL0325.1-2	LP hose 1/2" - 200mm
9	KSL0170.3-16	LP hose 3/16 170 mm
10	KSH0370.OO	HP hose E-E 950 mm
11	K0700.3-8	Sealing ring 3/8"
12	K0216	Coupling return hose M18x1.5mm
13	K0088	Suction hose pump
14	F023	Extension tank incl. F024
15	F020	Filter compl. >2008..
16	E2051	Connection block hydr.power pack >2010
17	E0634.12	Relay round TRBT 12V 150A
17	E0634.24	Relay round TRBT 24V 150A
18	E0551.29	Muff chuck straight E550.29
19	E0093.12	Lead through rubber 12mm
20	E0064.L	Connection motor LEFT
21	BMZ18.L	Nut low M18
22	BI08.055	Allenbolt with head M8x55
23	GK022	Air release cap orange 3/4

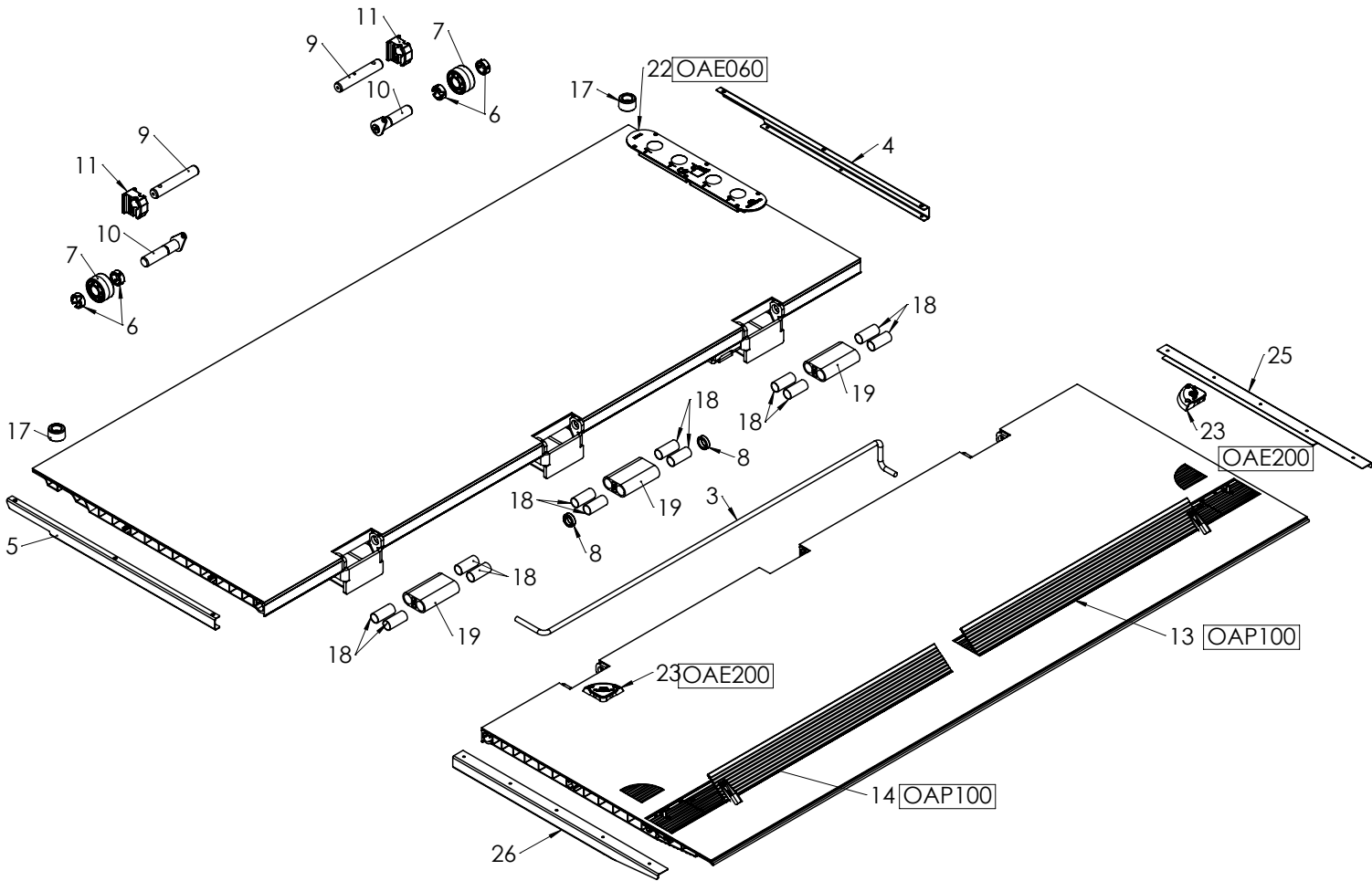

	Type
#	SM.10.01- 115
*	SM.10.01- 140
o	SM.20.03/SMR.20.03/SMP.20.03/SV.20.02/SP.20.02
&	SSU(R)80/SM.30.05

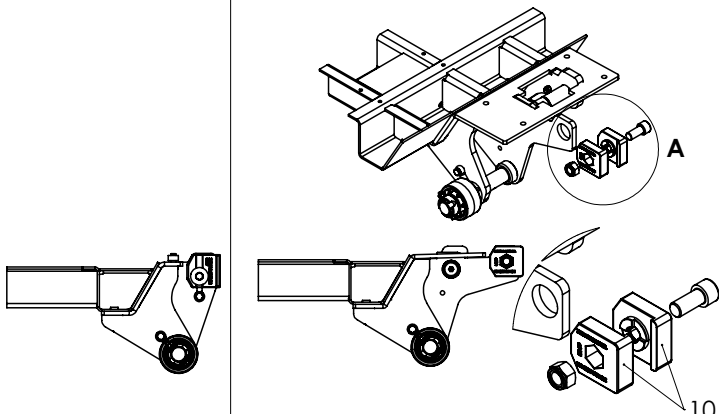
**Standard**
**Option: OAP312 [\$]**

Pos	Code	Description
1	XPA100.LE.W.S	Alu point SM7/8 LExW mm
2	XKA100.LE.O.CA.W.S	Fixed part alu SM7/8 LExW mm
3	VRX075.14	Torsion spring platform ø14
3	VRX075.13	Torsion spring platform ø13
3	VRX075.12	Torsion spring platform ø12
4	M3525.LE.R	Side lip plt right SM ...mm
5	M3525.LE.L	Side lip plt left SM ...mm
6	M1975.31.1	Ring platform roller pin ø30
7	M1975.31	Platform roller ø75/31x46mm
8	M1927.11	Spacer bush ø27.5-40x11 mm
&		
9	M1740.154.P50.L	Pin ø40x154mm - 50cc
o		
9	M1730.173.BO10	Pin ø30x173mm - BO10
o		
9	M1730.147.P50.L	Pin ø30x147mm - 50cc
*#		
9	M1725.102.P50.L	Pin ø25x102mm - 50cc
#		
10	M1725.087.P50.L	Pin ø25x87mm - 50cc
*		
10	M1725.100.P50.L	Pin ø25x100mm - 50cc
o		
10	M1730.139.P50.L	Pin ø30x139mm 50cc
&		
10	M1735.196.P50.L	Pin ø35x196mm - 50cc
11	M1417	End stop fixed part SM71-SMP10-...
12	M1409	End stop fixed part 60x66 (S245)
13	M0973.M.LE.R	Pallet stop right MECH. ...mm
14	M0973.M.LE.L	Pallet stop left MECH. ...mm
15	M0973.A.LE.R	Pallet stop right AUTOMAT. ...mm
16	M0973.A.LE.L	Pallet stop left AUTOMAT. ...mm
17	M0868.30	Rubber ring ø50x30mm
18	M0545	Bearing bush hinge PVC
19	M0544	Hinge platform point ALU 140mm
20	E0777.R	Foot control alu platform <2010
21	E0767.R	Foot control alu platform >2010
22	E0759.R	Foot control alu platform >2008
23	E0700	Set platform lights 12/24V >2005
24	E0700	Set platform lights 24V
25	M3527.950.R	Point right ALU 950mm
26	M3527.950.L	Point left ALU 950mm

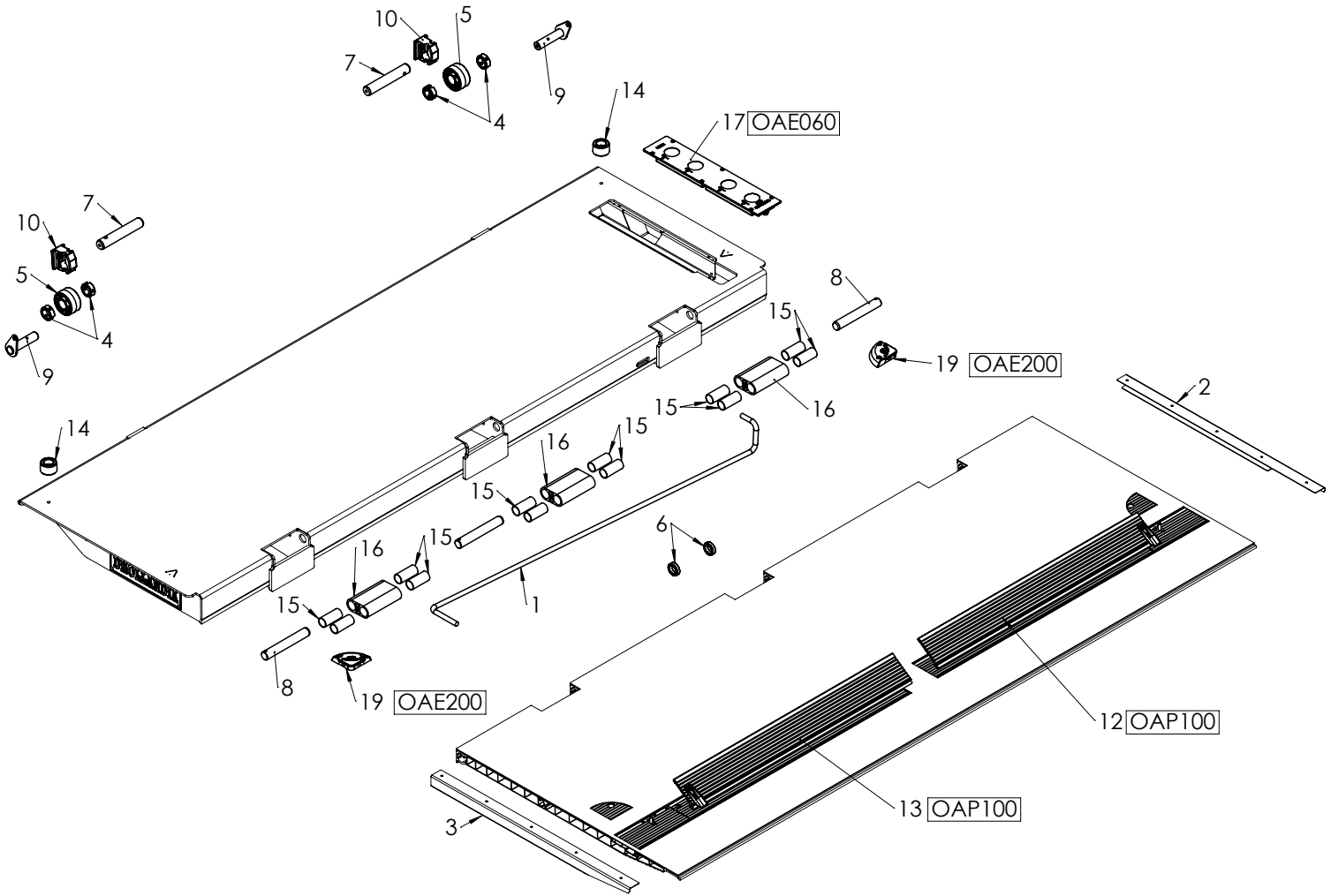

	Type
#	SM.10.01 - Used only one pins
o	SM.20.03/SMR.20.03/SMP.20.03/SV.20.02/SP.20.02
&	SSU(R)80/SM.30.05

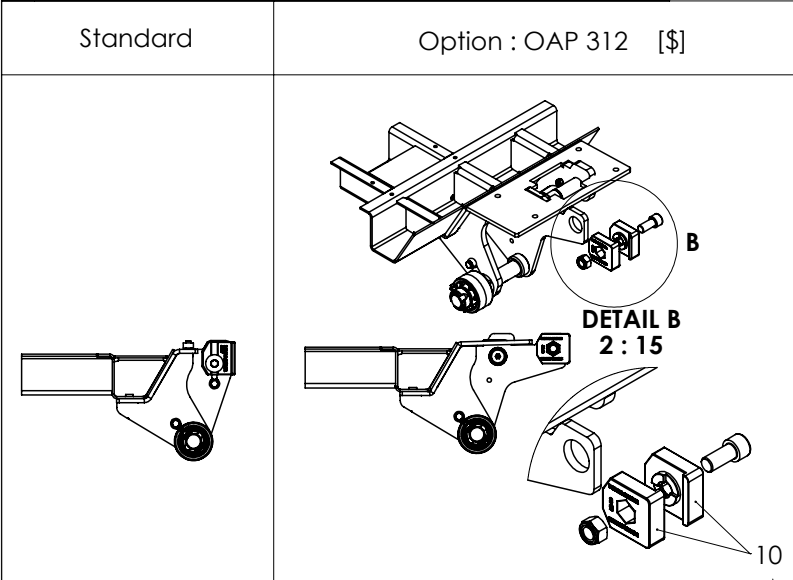

Pos	Code	Description
1	VRX075.14	Torsion spring platform ø14
1	VRX075.13	Torsion spring platform ø13
1	VRX075.12	Torsion spring platform ø12
2	M3527.950.R	Point right ALU 950mm
3	M3527.950.L	Point left ALU 950mm
4	M1975.31.1	Ring platform roller pin ø30
5	M1975.31	Platform roller ø75/31x46mm
6	M1927.11	Spacer bush ø27.5-40x11 mm
7	M1730.158.BO10	Pin ø30x158mm - BO10
&	M1740.154.P50.L	Pin ø40x154mm - 50cc
o	M1730.147.P50.L	Pin ø30x147mm - 50cc
8	M1727.182.BO08	Pin ø27x182mm - BO08
#	M1725.110.P50.R	Pin ø25x110mm - 50cc
o	M1730.204.P50.L	Pin ø30x204mm - 50cc
&	M1735.196.P50.L	Pin ø35x196mm - 50cc
10	M1417	End stop fixed part SM71-SMP10-...
11	M1409	End stop fixed part 60x66 (S245)
12	M0973.M.LE.R	Pallet stop right MECH. ....mm
12	M0973.A.LE.R	Pallet stop right AUTOMAT. ....mm
13	M0973.M.LE.L	Pallet stop left MECH. ....mm
13	M0973.A.LE.L	Pallet stop left AUTOMAT. ....mm
14	M0868.30	Rubber ring ø50x30mm
15	M0545	Bearing bush hinge PVC
16	M0544	Hinge platform point ALU 140mm
17	E0759.V	Foot control steel platform 2008-...
17	E0767.V	Foot control steel platform >2010
17	E0777.V	Foot control steel platform <2010
18	E0700	Set platform lights 24V
19	E0700	Set platform lights 12/24V >2005
20	E0278.H	Plate platform lights E0700